

FM57

Cast Iron Gate Valve

PN10

Features & Benefits

- Crane cast iron gate valves offer the ultimate in dependable service wherever minimum pressure drop is important
- Complete with Bronze trim
- Each valve is hydrostatically tested to BS EN 12266-1: 2003
- Manufactured in accordance with BS EN 1171: 2002

Materials

PART	MATERIAL	SIZES
Body	Cast Iron BS EN 1561 GJL-250	All
Bonnet	Cast Iron BS EN 1561 GJL-250	All
Bonnet Gasket	Asbestos Free	All
Disc	Cast Iron BS EN 1561 GJL-250	All
Stem	Brass BS 2874 CZ114	All
Stuffing Box	Cast Iron BS EN 1561 GJL-250	All
Gland	Cast Iron BS EN 1561 GJL-250	All
Stuffing Box Gasket	Asbestos Free	All
Packing	Asbestos Free	All
Handwheel	Cast Iron	All
Body Seat Ring	Bronze BS EN 1982 CC491K	All
Disc Stem Nut	Bronze BS EN 1982 CC491K	All
Disc Ring	Bronze BS EN 1982 CC491K	All

Dimensions & Weights

SIZE (mm)	WEIGHT (kg)	A (mm)	B (mm)	C (mm)	D (mm)	E (mm)	F (mm)
50	14	178	20	165	277	140	102
65	17	190	20	185	296	140	122
80	22	203	22	200	337	152	138
100	30	229	24	220	369	203	158
125	41	254	26	250	429	229	188
150	47	267	26	285	470	229	212
200	85	292	26	340	600	305	268
250	146	330	28	395	722	356	320
300	188	356	28	445	818	406	370



FM57

Dimensional Drawing

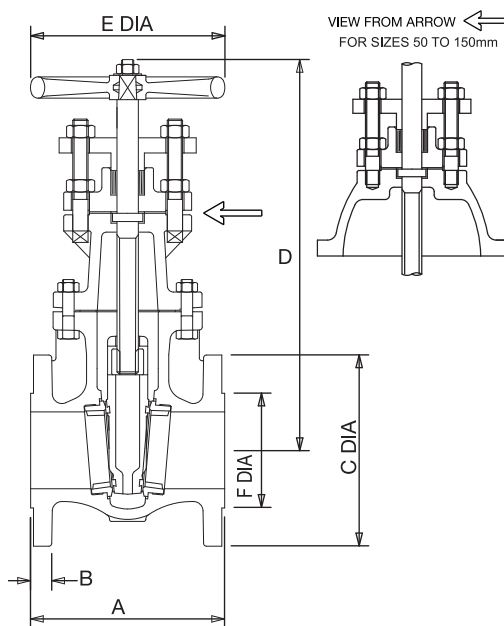

Pressure/Temperature Ratings

TEMPERATURE (°C)	-10 to 100	180
PRESSURE (BAR)	10	8.4

Intermediate pressure ratings shall be determined by interpolation.

PRESSURE RATING: PN10

TEMPERATURE OPERATING RANGE: -10 to 180°C

UK END CONNECTION: Flanged BS EN 1092-2: PN10

OPERATOR: Handwheel.

Gate valves are best for services that require infrequent valve operation, and where the disc is kept either fully opened or fully closed. They are not practical for throttling.

SPECIFICATION: Long Face-to-face, Wedge Disc, Non-Rising Stem.

Valves are manufactured in accordance with BS EN 1171: 2002. End flanges conform to BS EN 1092-2 PN10 with raised face and are normally supplied drilled.

This valve is not suitable for use on group 1 gases* or unstable fluids, as defined by the Pressure Equipment Directive 97/23/EC.

AVAILABLE OPTIONS: Flanges Undrilled, P50 Locking Device

* See page 230 for more information